

Ruijie Reyee RG-AirMetro550G-B Wireless Bridge

Installation Guide

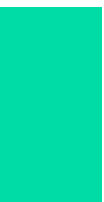
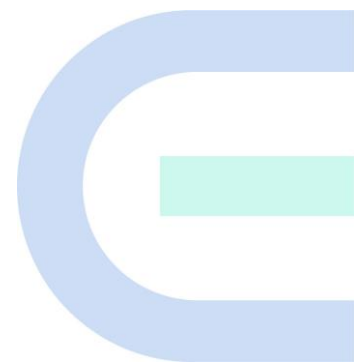

Copyright

Copyright © 2024 Ruijie Networks

All rights are reserved in this document and this statement.

Any reproduction, excerpt, backup, modification, transmission, translation or commercial use of this document or any portion of this document, in any form or by any means, without the prior written consent of Ruijie Networks is prohibited.

Trademarks including  are owned by Ruijie Networks.

All other trademarks or registered trademarks mentioned in this document are owned by their respective owners.

Disclaimer

The products, services, or features you purchase are subject to commercial contracts and terms, and some or all of the products, services, or features described in this document may not be available for you to purchase or use. Except for the agreement in the contract, Ruijie Networks makes no explicit or implicit statements or warranties with respect to the content of this document.

The names, links, descriptions, screenshots, and any other information regarding third-party software mentioned in this document are provided for your reference only. Ruijie Networks does not explicitly or implicitly endorse or recommend the use of any third-party software and does not make any assurances or guarantees concerning the applicability, security, or legality of such software. You should choose and use third-party software based on your business requirements and obtain proper authorization. Ruijie Networks assumes no liability for any risks or damages arising from your use of third-party software.

The content of this document will be updated from time to time due to product version upgrades or other reasons, Ruijie Networks reserves the right to modify the content of the document without any notice or prompt.

This manual is designed merely as a user guide. Ruijie Networks has tried its best to ensure the accuracy and reliability of the content when compiling this manual, but it does not guarantee that the content of the manual is completely free of errors or omissions, and all the information in this manual does not constitute any explicit or implicit warranties.

Preface

Audience

This document is intended for:

- Network engineers
- Technical support and servicing engineers
- Network administrators

Technical Support

- Official Website of Ruijie Reyee: <https://reyee.ruijie.com>
- Technical Support Website: <https://reyee.ruijie.com/en-global/support>
- Case Portal: <https://www.ruijienetworks.com/support/caseportal>
- Community: <https://community.ruijienetworks.com>
- Technical Support Email: service_rj@ruijienetworks.com
- Online Robot/Live Chat: <https://reyee.ruijie.com/en-global/rita>

Conventions

1. GUI Symbols

Interface symbol	Description	Example
Boldface	1. Button names 2. Window names, tab name, field name and menu items 3. Link	1. Click OK. 2. Select Config Wizard. 3. Click the Download File link.
>	Multi-level menus items	Select System > Time.

2. Signs

The signs used in this document are described as follows:

Warning

An alert that calls attention to important rules and information that if not understood or followed can result in data loss or equipment damage.

Caution

An alert that calls attention to essential information that if not understood or followed can result in function failure or performance degradation.

 **Note**

An alert that contains additional or supplementary information that if not understood or followed will not lead to serious consequences.

 **Specification**

An alert that contains a description of product or version support.

3. Note

This document provides the installation steps, troubleshooting, technical specifications, as well as the specifications and use guidelines of cables and connectors. It is intended for users who want to understand the above contents, and are familiar with the installation and maintenance of networking hardware.

Contents

Preface	I
1 Product Introduction	1
1.1 Overview	1
1.2 Package Contents.....	1
1.3 Appearance.....	1
1.3.1 Appearance.....	1
1.3.2 Ports, Buttons and LEDs	3
1.4 Technical Specifications	4
1.5 Power Supply Technical Specifications.....	6
2 Preparing for Installation	8
2.1 Safety Precautions.....	8
2.1.1 General Safety Precautions.....	8
2.1.2 Handling Safety.....	8
2.1.3 Electrical Safety	8
2.2 Installation Environment Requirements.....	9
2.2.1 Environment.....	9
2.2.2 Surge Protection	10
2.2.3 Temperature and Humidity.....	10
2.2.4 Anti-Interference.....	10
2.3 Tools	11
2.4 Checking Before Installation.....	11
3 Installation	12
3.1 Installation Procedure	12

3.2 Before You Begin.....	12
3.3 Safety Precautions During Installation	12
3.4 Installation Procedures	13
3.4.1 Installing the Wireless Bridge	13
3.4.2 Removing the Wireless Bridge	15
3.4.3 Installing the Antenna.....	17
3.5 Connecting Cables.....	24
3.6 Verifying the Installation.....	24
4 Debugging	25
4.1 Setting Up the Configuration Environment	25
4.2 Checking Environment Before/After Power-on.....	25
5 Monitoring and Maintenance.....	26
5.1 Monitoring	26
5.2 Hardware Maintenance.....	26
6 Common Troubleshooting	27
6.1 Troubleshooting Flowchart	27
7 Appendix.....	28
7.1 Connectors and Media.....	28

1 Product Introduction

1.1 Overview

The RG-AirMetro550G-B wireless bridge is launched by Ruijie Reyee. It utilizes the IEEE 802.11ac standard for efficient and reliable communication. Operating in the 5 GHz band and supporting 2x2 MIMO technology, this product delivers a maximum wireless rate of 867 Mbps for bridging, ensuring more than sufficient bandwidth for delivering point to point (PTP) and point to multi-point (PTMP) services. When mounted vertically, this wireless bridge can be adjusted within a range of ± 15 to 20 degrees, while when mounted horizontally, it can be adjusted along with the antenna. The RG-AirMetro550G-B wireless bridge can establish a mesh connection with other wireless bridges in 30 seconds by a simple press of the WPS button on this device.

1.2 Package Contents

Table 1-1 Package Contents

No.	Item	Quantity
1	RG-AirMetro550G-B Wireless Bridge	1
2	Power Cord	1
3	Power Adapter for Passive PoE Input, 24 V, 0.5 A	1
4	User Manual	1
5	Warranty Card	1

Note

The package contents above are intended to provide a general overview, and are subject to the terms of the order contract. Please check your goods carefully against the package contents or order contract. If you have any questions, please contact the distributor.

1.3 Appearance

1.3.1 Appearance

Figure 1-1 Appearance of the RG-AirMetro550G-B Wireless Bridge

Front view

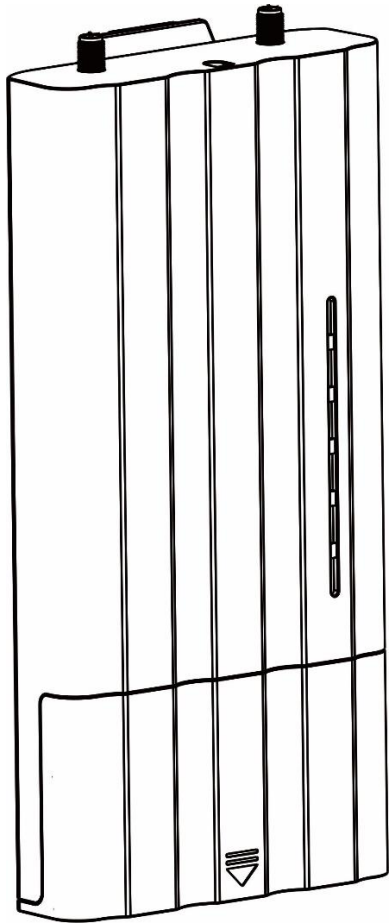

Back view

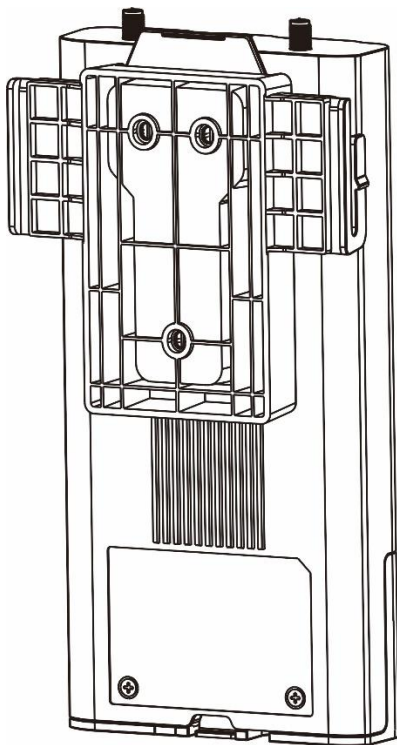

i Note

The label is located on the back of the device.

1.3.2 Ports, Buttons and LEDs

Figure 1-2 Ports, Buttons and LEDs of the RG-AirMetro550G-B Wireless Bridge

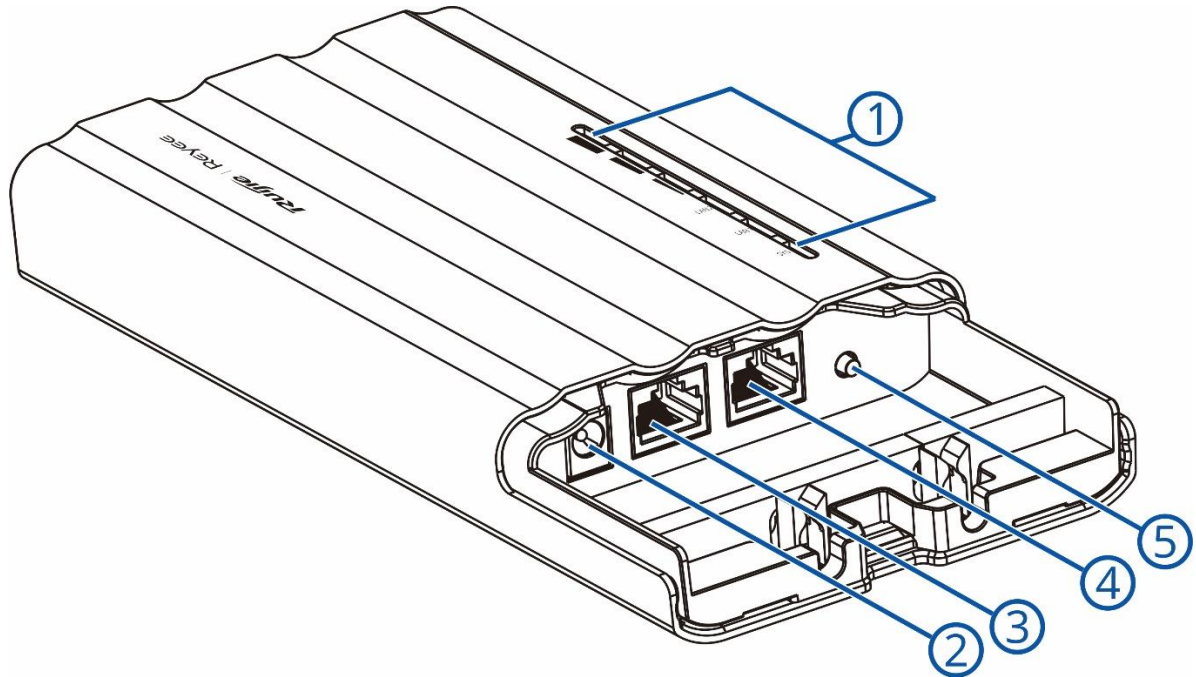

Table 1-2 Ports, Buttons and LEDs of the RG-AirMetro550G-B Wireless Bridge

Mark	Item	Description
1	Status LEDs	6 status LEDs, including 1 x system LED, 2 x port LED and 3 x signal LED
2	12 V DC power port	Connects to a 12 V 1 A DC adapter
3	LAN2 port	10/100/1000Base-T auto-negotiation port
4	LAN1/PoE port	10/100/1000Base-T auto-negotiation port, supporting power input from the shipped 24 V 0.5 A PoE adapter
5	Reset/WPS button	<p>Press and hold for less than 2 seconds: The device establishes a mesh connection with other devices in 30 seconds. (During mesh pairing, the signal LED on the device will continue blinking until the bridging process is completed.)</p> <p>Press and hold for 2 to 10 seconds: No action is triggered.</p> <p>Press and hold for more than 10 seconds: Restore the device to factory settings.</p>

Table 1-3 LEDs

LED	Status	Description
System LED	Solid green	The device is operating normally.
	Blinking	Fast blinking (8 to 10 times/second): The device is starting up. Fast blinking (2 times/second): The device is initializing. Fast blinking (2 times/second): The device is upgrading.
	Off	The device is NOT receiving power.
LAN1/LAN2 port LED	Solid green	A valid link is established, but the port is not receiving or sending data.
	Blinking green	A valid link is established, and the port is receiving or sending data.
	Off	No link is established.
Signal LEDs	Off	The device is not bridged.
	LED 1 on/blinking	The device is bridged.
	LED 1 on	The RSSI is above -75 dBm.
	LED 1 on, LED 2 blinking	The RSSI is above -73 dBm.
	LEDs 1 and 2 on	The RSSI is above -71 dBm.
	LEDs 1 and 2 on, LED 3 blinking	The RSSI is above -68 dBm.
	LEDs 1, 2, and 3 on	The RSSI is above -64 dBm.
	LEDs 1, 2, and 3 blinking	The mesh pairing is in progress.

1.4 Technical Specifications

Table 1-4 Specifications

Radio Design	<ul style="list-style-type: none"> ● 2.4 GHz single-stream ● 5 GHz dual-stream 2x2 MIMO
Protocol and Standard	IEEE 802.11 a/b/g/n/ac
Operating Frequency Bands	<ul style="list-style-type: none"> ● 2.4 GHz: 802.11 b/g/n: 2.4000 GHz to 2.483 GHz ● 5 GHz: 802.11a/n/ac: 5.150 GHz to 5.350 GHz, 5.470 GHz to 5.725 GHz, 5.725 GHz to 5.850 GHz <p> Note Country-specific restrictions apply.</p>

	<ul style="list-style-type: none"> ● European Union & United Kingdom: 2400-2483.5 MHz, EIRP ≤ 20 dBm 5470-5725 MHz, EIRP ≤ 30 dBm ● Myanmar: 2400-2483.5 MHz, EIRP ≤ 23 dBm 5725-5825 MHz, EIRP ≤ 30 dBm ● Thailand: 2.4 GHz to 2.4835 GHz: 20 dBm 5.725 GHz to 5.825 GHz: 30 dBm ● Indonesia: 2400-2483.5 MHz, EIRP ≤ 27 dBm 5725-5825 MHz, EIRP ≤ 23 dBm ● Egypt: 2400-2483.5 MHz, EIRP ≤ 20 dBm 5150-5350 MHz, EIRP ≤ 23 dBm
Antenna Type	Internal 2.4 GHz PCB onboard antenna and external 5 GHz antenna
Bridging Signal Strength	2/5/10 km (when mounted on a 360°, 120°, or 90° antenna)
Spatial Streams	2x2 MIMO
Data Rate	<ul style="list-style-type: none"> ● 2.4 GHz: 150 Mbps ● 5 GHz: 867 Mbps
Modulation Technology	<ul style="list-style-type: none"> ● OFDM: BPSK@6/9Mbps, QPSK@12/18Mbps, 16-QAM@24/36Mbps, 64-QAM@48/54Mbps ● MIMO-OFDM: BPSK, QPSK, 16-QAM, 64-QAM, 256-QAM
Receive Sensitivity	<ul style="list-style-type: none"> ● 11a: -89dBm (6Mbps), -80dBm (24Mbps), -76dBm (36Mbps), -71dBm (54Mbps) ● 11n: -83dBm@MCS0, -65dBm@MCS7, -83dBm@MCS8, -65dBm@MCS15 ● 11ac: -86dBm(MCS0), -63dBm(MCS9)
Max. Transmit Power	≤ 400 mW (26 dBm) (adjustable)
Power Step	1 dBm
Dimensions (L x W x H)	200 mm x 98.5 mm x 29 mm (7.87 in. x 3.88 in. x 1.14 in.) (excluding the mounting bracket)
Net Weight	0.68 kg (1.50 lbs.)
Service Ports	2 x 10/100/1000Base-T auto-negotiation ports, where LAN1/PoE port supports 24 V PoE input
Buttons	1 x reset/WPS button
LED	1 x system LED, 2 x port LED, and 3 x signal LED
Power Supply	<ul style="list-style-type: none"> ● 24 V Passive PoE input (shipped with a 24 V PoE adapter) ● 12 V 1 A DC adapter for DC power input
Max. Power Consumption	≤ 12 W
Environment	<p>Operating temperature: -40°C to +80°C (-40°F to +176°F) (excluding the power adapter)</p> <p>(Note: When a power adapter is used, the maximum operating temperature for both the device and the power adapter is 60°C (140°F).)</p> <p>Storage temperature: -40°C to 85°C (-40°F to +185°F)</p>

	Operating humidity: 5% to 95% RH (non-condensing)
	Storage humidity: 5% to 95% RH (non-condensing)
Installation	Directly mounted onto an antenna
IP Rating	IP55
Flame Rating	UL94V-0
Certification	CE
MTBF	> 400000 hrs

Warning

Operation of this equipment in a residential environment could cause radio interference.

Note

The weight in the above table indicates the net weight of a single unit.

1.5 Power Supply Technical Specifications

The RG-AirMetro550G-B wireless bridge supports 12 V, 1 A DC power input or 24 V PoE input, and is shipped with a 24 V, 0.5 A Passive PoE adapter.

- Technical specifications of the PoE adapter:

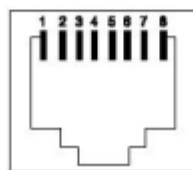
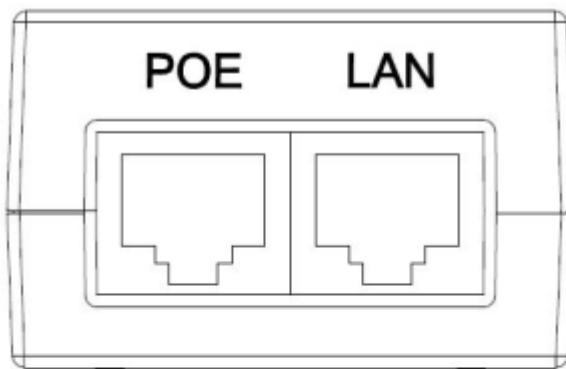

(1) RJ45 LAN port: Pins 1, 2, 3, 4, 5, 6, 7 and 8 are for data transmission.

(2) RJ45 PoE port: Pins 1, 2, 3, 4, 5, 6, 7 and 8 are for data transmission, with positive on pins 4 and 5 and negative on pins 7 and 8.

- Technical specifications of the DC adapter:

Inner Diameter	Outer Diameter	Depth
2.10 ± 0.05 mm (0.083 in. ± 0.002 in.)	5.50 ± 0.05 mm (0.22 in. ± 0.002 in.)	9 mm (0.35 in.)

! Warning

- For DC power supply, the DC adapter required for this wireless bridge is not included in the package. You can purchase the DC adapter separately from us.
 - For PoE power supply, use the provided PoE adapter in the package. Do not use other models of PoE adapters or switches for power supply as it may lead to irreparable damage to the device.
-

2 Preparing for Installation

2.1 Safety Precautions

Note

- To prevent device damage and physical injury, please read carefully the safety precautions described in this chapter.
 - The following safety precautions do not cover all possible dangers.
-

2.1.1 General Safety Precautions

- Do not expose the device to high temperature, dusts, or harmful gases. Do not install the device in an inflammable or explosive environment. Keep the device away from EMI sources such as large radar stations, radio stations, and substations. Do not subject the device to unstable voltage, vibration, and noises.
 - The installation site should be far away from the sea. Keep the device at least 500 meters (1640 ft.) away from the seaside and do not face it toward the wind from the sea.
 - The installation site should be free from water flooding, seepage, dripping, or condensation. The installation site shall be selected according to network planning and features of communications device, and considerations such as climate, hydrology, geology, earthquake, electric power, and transportation.
-

Caution

Please follow the correct procedures described in this guide to install and remove the device.

2.1.2 Handling Safety

- Avoid frequently handling the device.
- Cut off all the power supplies and unplug all power cords before moving or handling the device.

2.1.3 Electrical Safety

Warning

- Improper or incorrect electrical operations may cause a fire, electric shock, and other accidents, and lead to severe and fatal personal injury and device damage.
 - Direct or indirect contact with high voltage or mains power supply via wet objects may cause fatal dangers.
-

- Observe local regulations and specifications during electrical operations. Only personnel with relevant qualifications can perform such operations.
- Check whether there are potential risks in the work area. For example, check whether the power supply is grounded, whether the grounding is reliable, and whether the ground is wet.

2.2 Installation Environment Requirements

To ensure normal operation and a prolonged service life of the device, the installation site must meet the following requirements.

2.2.1 Environment

- Install the device in a well-ventilated environment. If it is installed in a closed room, make sure there is a good cooling system.
- Make sure the site is sturdy enough to support the device and its accessories.
- Make sure the site has enough space for installing the device and leave sufficient space around the device for ventilation.

Bridge Type	Distance Between Base Station and Customer Premises Equipment (CPE)	Recommended Installation Height (Above the Obstacle)
5 GHz bridge	500 m (0.13 mi.)	2.6 m (8.53 ft.)
	1 km (0.62 mi.)	3.5 m (11.48 ft.)
	2 km (1.24 mi.)	5.2 m (17.06 ft.)
	3 km (1.86 mi.)	6.3 m (20.67 ft.)
	4 km (2.49 mi.)	7.3 m (23.95 ft.)
	5 km (3.11 mi.)	8.2 m (26.9 ft.)
	6 km (3.73 mi.)	9 m (29.53 ft.)
	7 km (4.35 mi.)	9.7 m (31.82 ft.)
	8 km (4.97 mi.)	10.5 m (34.45 ft.)
	9 km (5.59 mi.)	11 m (36.09 ft.)
	10 km (6.21 mi.)	11.6 m (38.06 ft.)
	11 km (6.84 mi.)	12 m (39.37 ft.)
	12 km (7.46 mi.)	12.8 m (41.99 ft.)
	13 km (8.08 mi.)	13.3 m (43.64 ft.)
	14 km (8.70 mi.)	13.8 m (45.28 ft.)
15 km (9.32 mi.)	14.3 m (46.92 ft.)	
2.4 GHz bridge	50 m (164.04 ft.)	1.2 m (3.94 ft.)
	100 m (328.08 ft.)	1.7 m (5.58 ft.)
	300 m (984.25 ft.)	3 m (9.84 ft.)

Bridge Type	Distance Between Base Station and Customer Premises Equipment (CPE)	Recommended Installation Height (Above the Obstacle)
	500 m (1640.42 ft.)	4 m (13.12 ft.)

2.2.2 Surge Protection

- When the connection cable between the main grounding conductor and local equipotential earthing terminal board (LEB) on each floor is short, use a stranded copper wire with a sectional area not less than 1.318 mm² (16 AWG) for the connection cable.
- Use a shielded network cable if possible. Ensure that devices connected to both ends of the shielded network cable are reliably grounded, and that the sheath of the shielded network cable is also grounded if possible. If no shielded network cable is available, wire the network cable through a steel pipe and bury the steel pipe for lead-in, and properly ground both ends of the steel pipe.
- The device has a built-in high-grade surge arrester with a 6KV surge protection capability. Generally, additional surge arrester is not required. If a higher surge protection level is required, a surge arrester can be installed and must be grounded.

2.2.3 Temperature and Humidity

To ensure the normal operation and prolonged service life of the device, maintain an appropriate temperature and humidity in the equipment room. The equipment room with too high or too low temperature and humidity for a long period may damage the device.

- In an environment with high humidity, the insulating material may have bad insulation or even leak electricity and sometimes the materials may suffer from mechanical performance change and metallic parts may get rusted.
- In an environment with low humidity, the insulating strip may dry and shrink, and static electricity is prone to occur and damage the internal circuits of the device.
- In an environment with high temperature, the device is subjected to even greater harm, as its performance may degrade significantly and its useful life may be shortened in the case of long-term exposure that expedites the aging process.

Table 2-1 Temperature and Humidity Requirements

Operating Temperature	Operating Humidity
-40°C to +80°C (-40°F to +176°F)	5% to 95% RH (non-condensing)

2.2.4 Anti-Interference

- Take interference prevention measures for the power supply system.
- Keep the device away from the grounding facility or lightning and grounding facility of the power device as much as possible.
- Keep the device away from high-power radio stations, radar stations, and high-frequency high-current devices.

2.3 Tools

Table 2-2 Tools

Common Tools	Marker, Phillips screwdriver, hammer drill, power cords, Ethernet cables, and diagonal plier
Special Tools	Anti-ESD gloves, wire stripper, crimping plier, RJ45 crimping plier, wire cutter, and waterproof adhesive tape
Meters	Multimeter
Relevant Devices	PC, display, and keyboard

 **Note**

The RG-AirMetro550G-B wireless bridge is not shipped with a tool kit. You need to prepare a tool kit by yourself.

2.4 Checking Before Installation

After unpacking the product, carefully inspect each item in accordance with the provided package contents. If any inconsistencies are found, please contact our local distributor.

3 Installation

Caution

Before installing the device, make sure that you have carefully read the requirements described in Chapter 2.

3.1 Installation Procedure

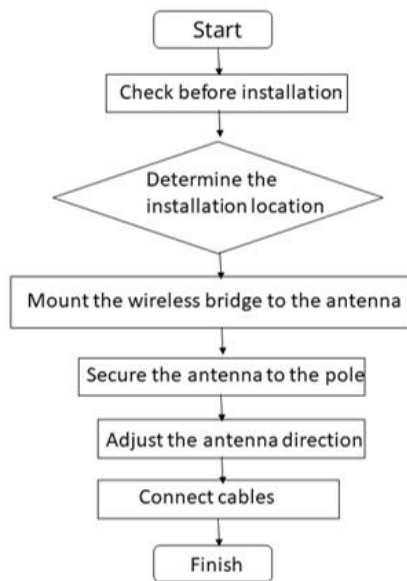

3.2 Before You Begin

Carefully plan and arrange the installation location, networking mode, power supply, and cabling of the device before installation. Confirm the following points before installation:

- The installation site provides sufficient space for heat dissipation.
- The installation site meets the temperature and humidity requirements of the device.
- The power supply and required current are available in the installation site.
- The selected power supply modules meet the system power requirement.
- The network cables have been deployed in the installation site.
- The installation site meets all requirements described in this guide.
- The device meets the customers' requirements.

3.3 Safety Precautions During Installation

To ensure minimal interference when installing multiple wireless bridges in close proximity, maintain a horizontal installation distance of at least 2 meters, or a vertical installation distance of at least 0.5 meters between each

wireless bridge. Ensure that the horizontal angle formed by the two wireless bridges is greater than 120 degrees. The specific installation location of the wireless bridge should be determined by professionals after conducting a thorough site survey.

Before installation, ensure that the installation location meets the requirements in 2.2.1 , and pay attention to the following:

- Use the provided power adapter (24 V, 0.5 A PoE power adapter, with positive on pins 4 and 5 and negative on pins 7 and 8), or an alternative power supply with identical specifications to supply power to this device. Do not use power adapters with different specifications.
- The supplied PoE adapter supports Cat5e or better Ethernet cables for power supply for up to 100 meters (328 ft.). Prior to connecting the Ethernet cable, ensure that the power module switch is in the off position.
- Ensure the Ethernet cables and power cords are securely connected.

3.4 Installation Procedures

Caution

- Install the device in a manner that maximizes the coverage area of the antenna.
- The schematic diagram provided is for reference purposes only. The actual product should be installed based on its physical specifications and design.

3.4.1 Installing the Wireless Bridge

This wireless bridge can be mounted onto 90°, 120°, or 360° antennas. The installation procedure is the same. The following section describes the installation procedure for the 90° antenna.

- (1) Connect the RF cable to the SMA connector of the wireless bridge.

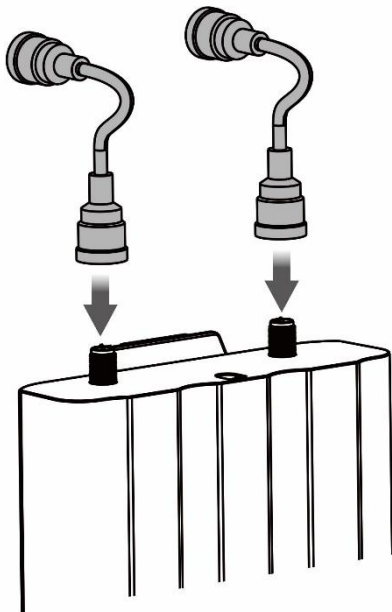

- (2) Attach the wireless bridge to the antenna.

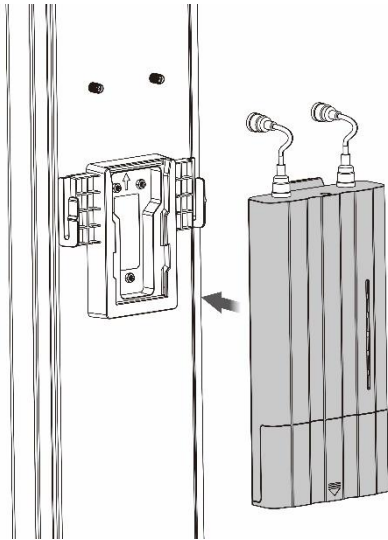

(3) Connect the SMA connector of the wireless bridge to that of the antenna.

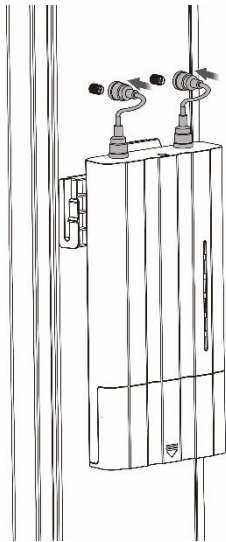

(4) Install the protective cover.

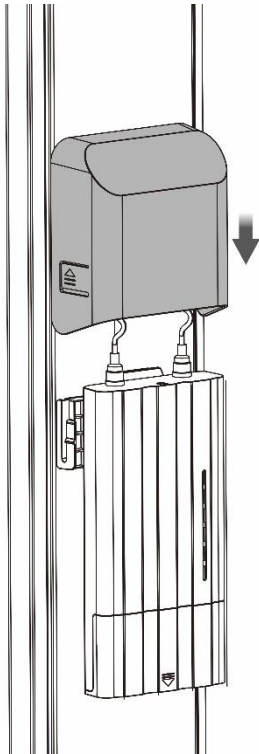

3.4.2 Removing the Wireless Bridge

- (1) Remove the protective cover by pulling it upward.

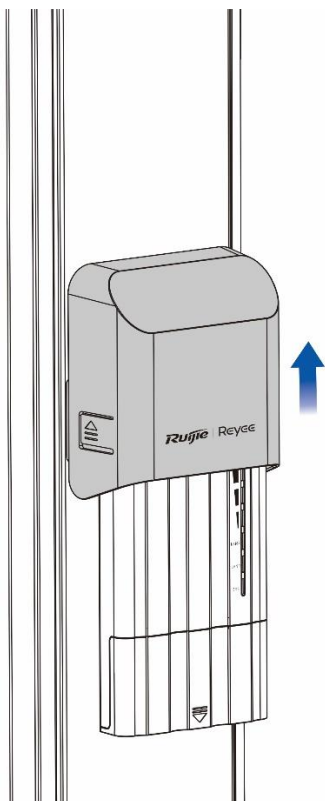

- (2) Unscrew the RF cable.



(3) Remove the wireless bridge by pulling it upward and then outward.

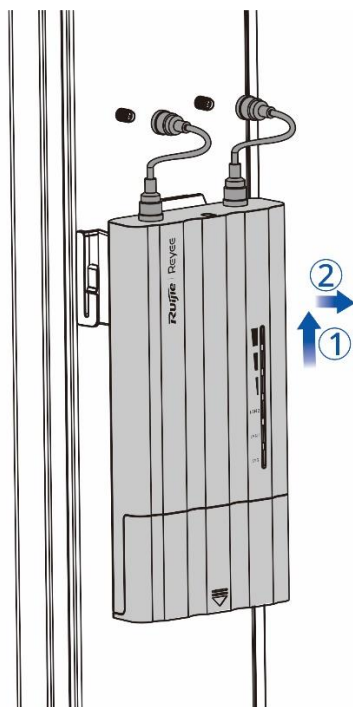

(4) Remove the RF cable.

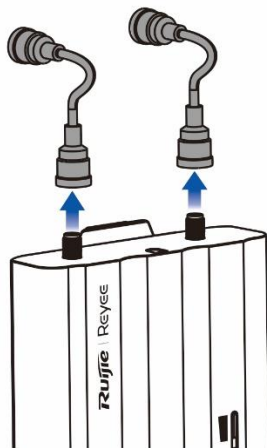

3.4.3 Installing the Antenna

i Note

You are advised to use the following three Ruijie antenna models: RG-ANT20S-90, RG-ANT16S-120, and RG-ANT13-360.

- Installing a 90° antenna

(1) Secure the upper and lower brackets to the antenna with four screws, two for each bracket.

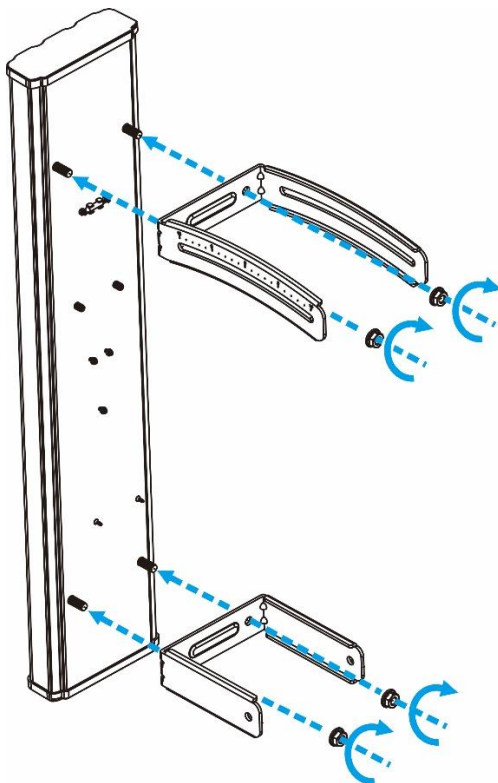

(2) Secure the two fastening pieces to the upper and lower brackets with four screws, two for each.

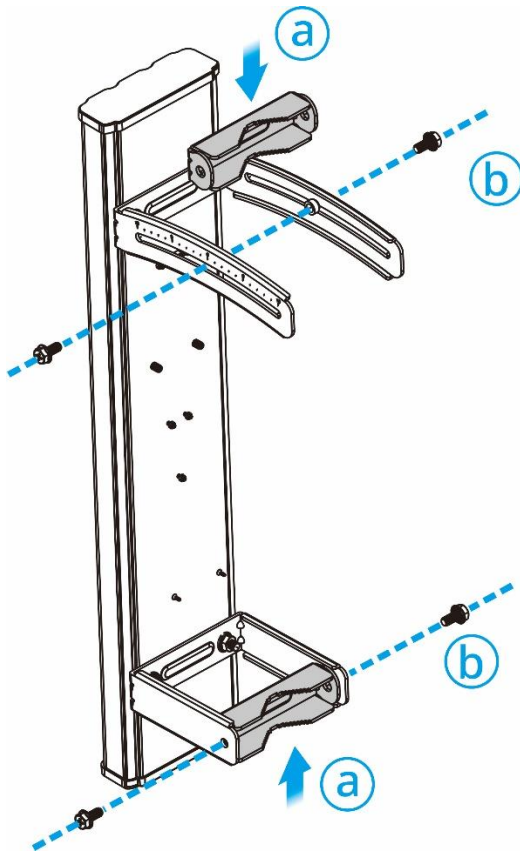

(3) Secure the antenna to the pole.

i Note

M8 x 150 mm screws are recommended.

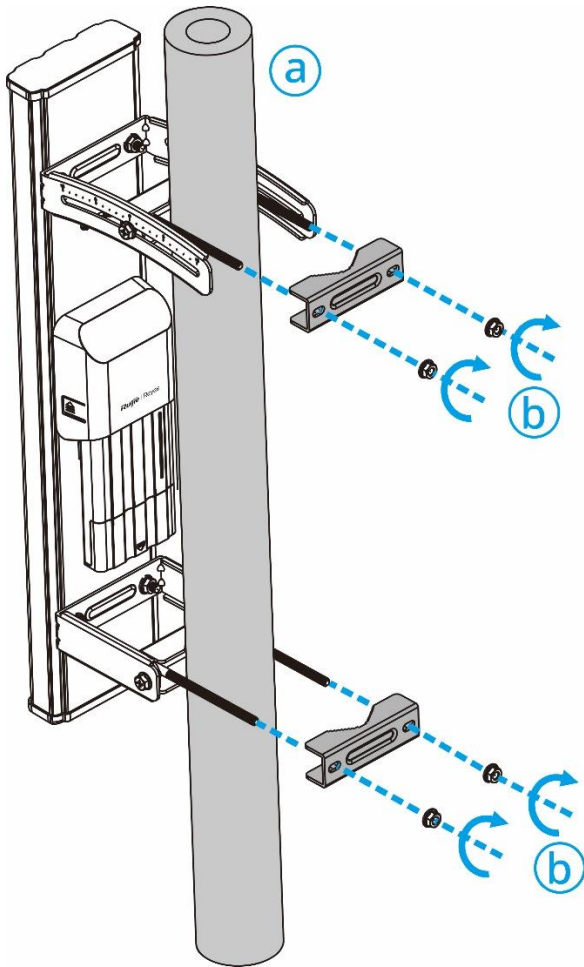

(4) The installation is complete.

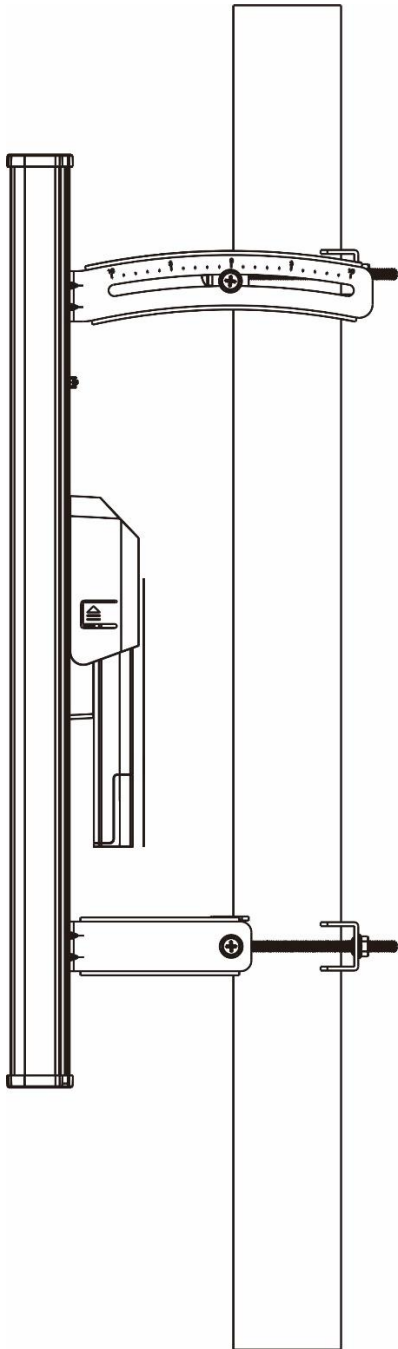

- Installing a 120° antenna
 - (1) Secure the mounting bracket to the antenna with four screws.

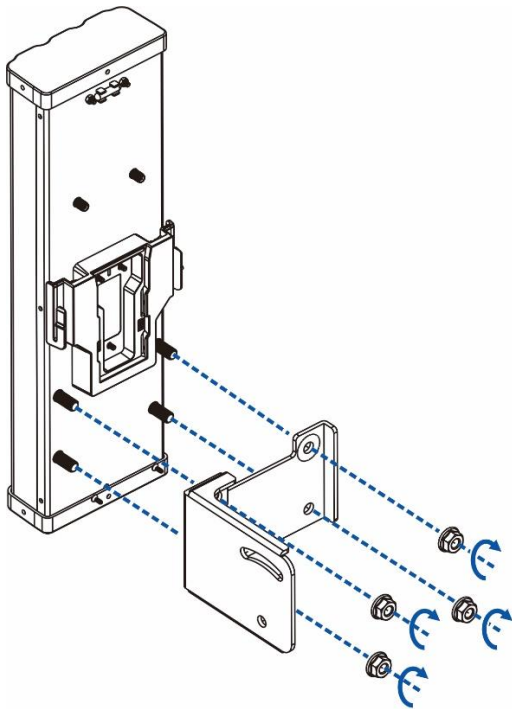

(2) Attach the bracket holder to the bracket with two screws.

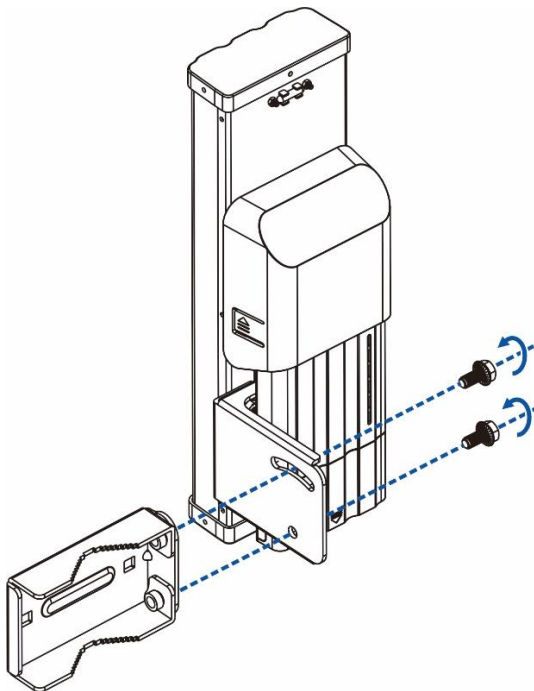

(3) Secure the antenna to the pole.

i Note

M8 x 150 mm screws are recommended.

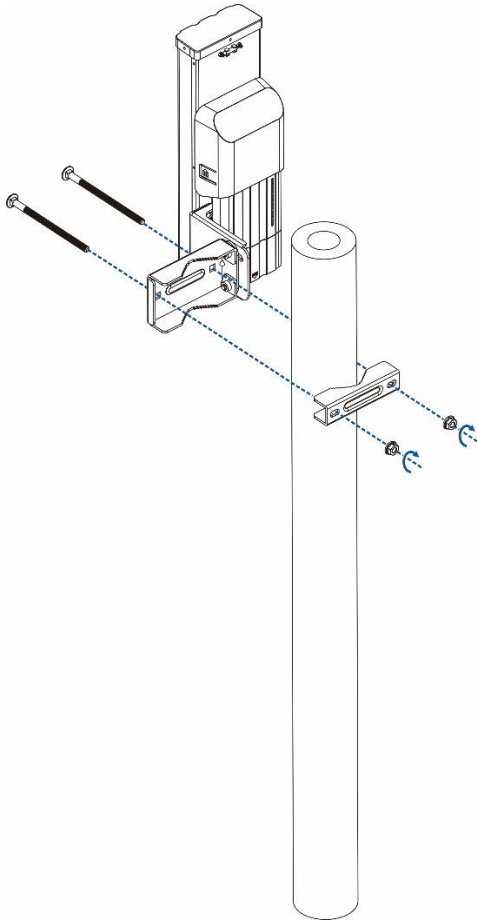

- Installing a 360° antenna

(1) Secure the antenna to the pole.

i Note

M8 x 150 mm screws are recommended.

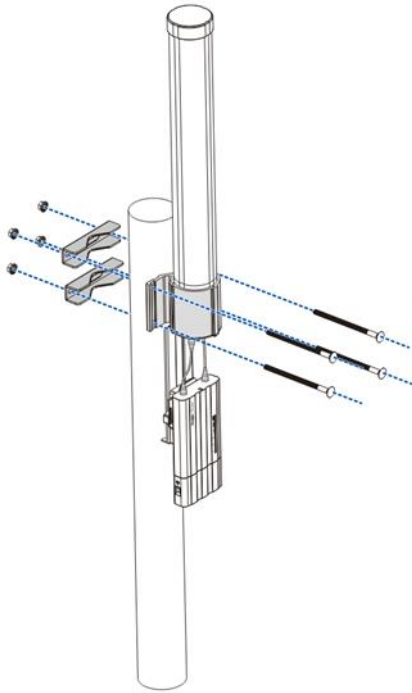

(2) The installation is complete.

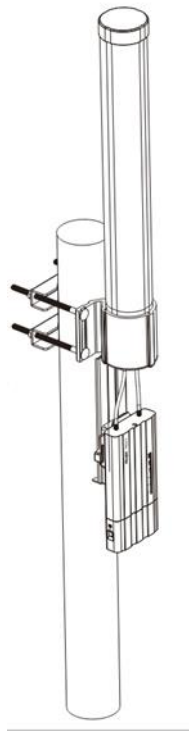

3.5 Connecting Cables

- (1) Use or make an Ethernet cable based on the distance between the wireless bridge and the power source. The device supports PoE power supply over Cat5e or better cables with a cable length up to 100 meters (328 ft.).
- (2) Connect the PoE port of the 24 V PoE adapter to the LAN1/PoE port of the wireless bridge using an Ethernet cable. Connect the LAN port of the PoE adapter to the server or camera using another Ethernet cable. Alternatively, connect the 12 V DC adapter to the DC port of the wireless bridge for power supply, and then connect the LAN port of the wireless bridge to the server or camera using another Ethernet cable.

Figure 3-1 Cable Connection

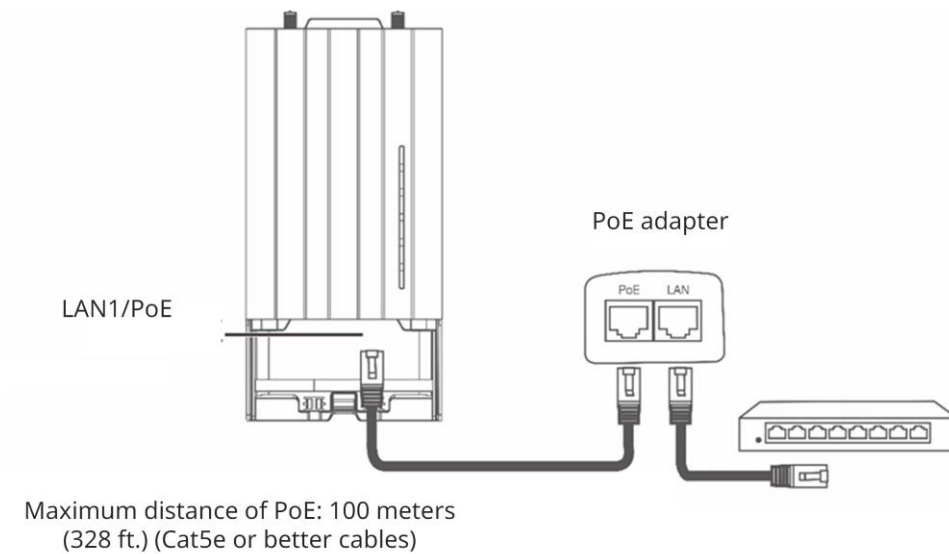

Warning

- After the Ethernet cable is securely connected to the device, cover the device with a waterproof cover to shield it from potential water and dust damage.
 - Do not use other models of PoE adapters or switches for power supply as it may lead to irreparable damage to the device.
-

3.6 Verifying the Installation

- (1) Check the device
 - Verify that the external power supply matches the device.
 - Verify that the device is firmly and reliably secured.
- (2) Check the power supply
 - Verify that the power cord is properly connected and meet safety requirements.
 - Turn on the power supply to supply power to the device. Verify that the device works properly.

4 Debugging

4.1 Setting Up the Configuration Environment

Before setting up the configuration environment using the 24 V, 0.5 A PoE power supply or the 12 V DC power supply, verify that the power cord is properly connected and that the configuration environment meets safety requirements.

4.2 Checking Environment Before/After Power-on

(1) Before power-on, check the following:

- Verify that the power supply is properly connected.
- Verify that the input voltage matches the specification.

(2) After power-on, check the following (Recommended):

- Verify that the LED status is normal.

5 Monitoring and Maintenance

5.1 Monitoring

You can observe the LED status to monitor the device in operation.

5.2 Hardware Maintenance

If the hardware is faulty, please contact Ruijie Networks technical support for assistance.

6 Common Troubleshooting

6.1 Troubleshooting Flowchart

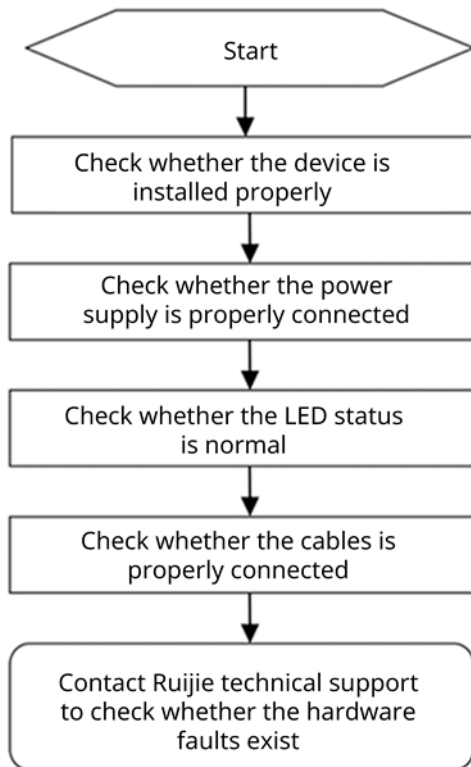

7 Appendix

7.1 Connectors and Media

1000BASE-T/100BASE-TX/10BASE-T Port

The 1000BASE-T/100BASE-TX/10BASE-T port is a 10/100/1000 Mbps auto-negotiation port that supports auto MDI/MDIX Crossover.

Compliant with IEEE 802.3ab, the 1000BASE-T port requires Category 5e 100-ohm UTP or STP (recommended) with a maximum distance of 100 meters (328 feet).

The 1000BASE-T port requires all four pairs of wires to be connected for data transmission. The following figure shows the four pairs of wires for the 1000BASE-T port.

Figure 7-1 1000BASE-T Twisted Pair Connections

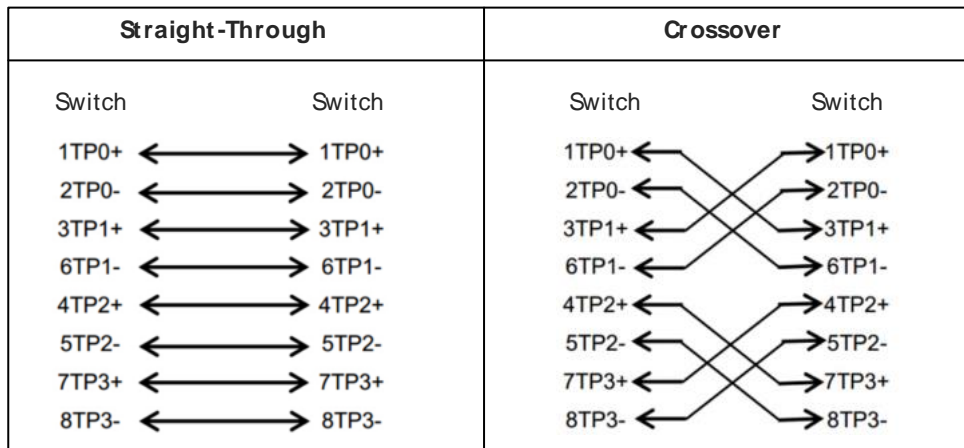

100BASE-TX/10BASE-T can be interconnected using cables of the preceding specifications. For 10 Mbps, the 100BASE-TX/10BASE-T port can be connected using 100-ohm Category 3, Category 4, and Category 5 cables; for 100 Mbps, the 100BASE-TX/10BASE-T port can be connected using 100-ohm Category 5 cables with a maximum connection distance of 100 meters. The following table shows 100BASE-TX/10BASE-T pin assignments.

Table 7-1 100BASE-TX/10BASE-T Pin Assignments

Pin	Socket	Plug
1	Input Receive Data+	Output Transmit Data+
2	Input Receive Data-	Output Transmit Data-
3	Output Transmit Data+	Input Receive Data+
6	Output Transmit Data-	Input Receive Data-
4, 5, 7, 8	Not Used	Not Used

The following figure shows feasible connections of the straight-through and crossover twisted pair cables for a 100BASE-TX/10BASE-T port.

Figure 7-2 100BASE-TX/10BASE-T Twisted Pair Connections

